

Shrink Disc Type HYD

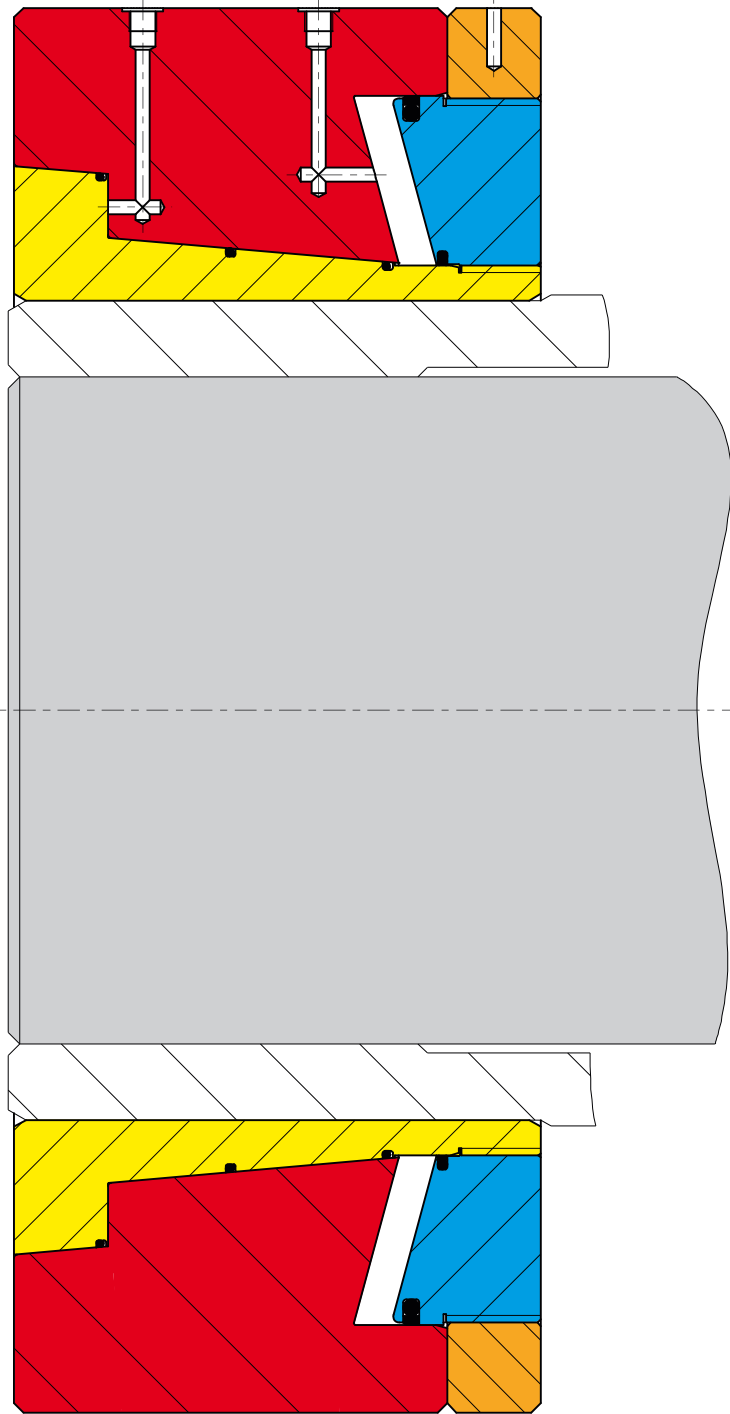

Shrink Disc HYD

Series 22

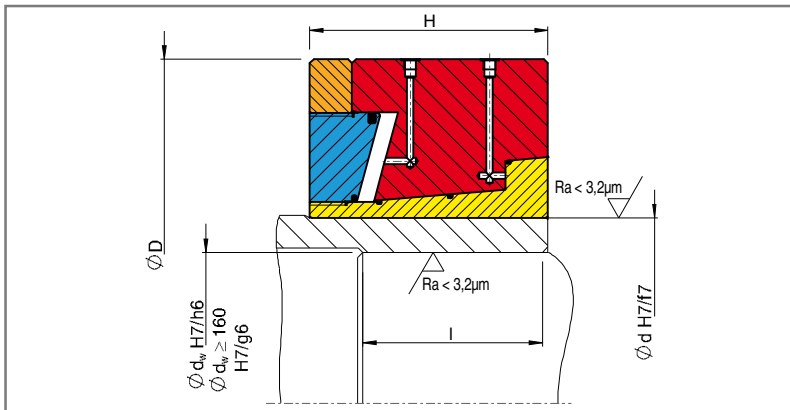

Code:

M_t maximum transmissible torque of a shrink disc with $P_{ax}=0$

P_{ax} maximum transmissible axial load with $M_t=0$

Type	d mm	d _w mm	M _t kNm	P _{ax} kN	max. hyd. press bar	D mm	l mm	H mm	kg
HYD 62 - 22		50	2,7	107	450	130	25	60	5
		52	3,0	114					
		53	3,1	118					
HYD 80 - 22		55	3,1	112	450	155	25	60	6
		60	3,9	130					
		65	4,8	148					
HYD 100 - 22		70	7,6	217	450	185	34	70	10
		75	9,0	241					
		80	10,6	265					
HYD 125 - 22		90	18	390	450	230	42	75	16
		95	20	421					
		100	23	453					
HYD 140 - 22		100	25	495	450	263	46	84	24
		105	28	529					
		110	31	563					
HYD 155 - 22		110	33	592	450	300	50	90	34
		150	36	628					
		120	40	663					
HYD 165 - 22		120	40	667	450	320	56	90	39
		125	44	706					
		130	48	744					
HYD 175 - 22		130	50	770	450	320	56	90	37
		135	55	809					
		140	59	849					
HYD 185 - 22		140	74	1058	450	340	71	117	55
		145	80	1107					
		150	87	1157					
HYD 200 - 22		150	86	1148	450	370	71	117	65
		160	100	1247					
		165	107	1296					
HYD 220 - 22		160	105	1311	450	405	92	140	93
		170	121	1425					
		180	139	1540					
HYD 240 - 22		180	145	1610	450	430	92	140	103
		190	165	1732					
		200	186	1855					
HYD 260 - 22		200	199	1991	450	460	103	160	133
		210	223	2124					
		220	248	2259					

When ordering please state : e.g. HYD 155 - 22 x 150 (Type x Ø d)

Series 22

Type	d mm	d _w mm	M _t kNm	P _{ax} kN	max. hyd. press bar	D mm	l mm	H mm	kg
HYD 280 - 22	280	220	285	2593	450	485	122	180	163
		230	316	2747					
		240	348	2902					
HYD 300 - 22	300	230	326	2837	450	520	122	180	187
		240	359	2994					
		250	394	3153					
HYD 320 - 22	320	250	397	3178	450	570	134	220	282
		260	435	3344					
		270	474	3512					
HYD 340 - 22	340	260	541	4158	450	640	144	220	372
		270	588	4359					
		280	638	4560					
HYD 360 - 22	360 350	280	646	4616	450	660	144	220	388
		290	699	4819					
		300	753	5023					
HYD 390 - 22	390 380	310	791	5103	450	690	144	220	410
		320	849	5307					
		330	909	5511					
HYD 420 - 22	420	330	850	5153	450	720	172	255	502
		340	910	5352					
		350	972	5553					
HYD 440 - 22	440	340	915	5385	450	740	172	255	520
		350	977	5585					
		360	1041	5786					
HYD 460 - 22	460	360	1016	5643	450	760	172	255	537
		370	1080	5839					
		380	1147	6036					
HYD 480 - 22	480	380	1386	7293	450	830	188	295	779
		390	1468	7526					
		400	1552	7760					
HYD 500 - 22	500	400	1720	8600	450	850	188	295	803
		410	1816	8859					
		420	1915	9118					
HYD 530 - 22	530	430	2141	9959	450	910	213	330	1040
		440	2252	10237					
		450	2366	10516					
HYD 560 - 22	560	450	2397	10653	450	980	213	330	1229
		460	2515	10934					
		470	2636	11216					
HYD 590 - 22	590	470	2726	11600	450	1020	228	360	1435
		480	2854	11892					
		490	2985	12185					
HYD 620 - 22	620	500	3203	12810	450	1070	254	360	1577
		510	3345	13119					
		520	3491	13428					
HYD 660 - 22	660	530	4079	15393	450	1160	260	380	1991
		540	4248	15732					
		550	4420	16073					
HYD 700 - 22	700	560	4501	16076	450	1210	280	420	2356
		580	4858	16752					
		600	5229	17430					
HYD 750 - 22	750	600	5209	17363	450	1260	300	450	2656
		620	5594	18044					
		640	5992	18726					
HYD 800 - 22	800	640	6108	19086	450	1310	340	480	2974
		660	6534	19802					
		680	6977	20519					

Further sizes on request. Technical changes to be reserved without notice.
When ordering please state : e. g. HYD360 - 22x360 (Type x Ø d)

Mounting and Removal Instructions for Shrink Disc Type HYD 22

The STÜWE® shrink discs type HYD are supplied ready to be mounted. The pressure chamber contains hydraulic oil.



Mounting

1. Shaft and hub must be absolutely free of grease in the fit area. Full torque transmission is absolutely dependant on this measure. Do not use contaminated cleaning solvents and unclean rags.
2. Slide the shrink disc onto the hub. The outer surface of the hub may be greased.



The shrink disc has to be in contact with the hub on its full length. Do not tighten the shrink disc before the shaft is mounted!

3. Fit the shaft or slide the hub onto the shaft.
4. Remove screw plugs from the "Spannen" (Tighten) and "Entspannen" (Loosen) connections. Collect any oil leakage.
5. Connect pressure line to the connection marked "Spannen" (Tighten).
6. Tighten the shrink disc by applying hydraulic pressure. The correct tightening force is reached as soon as the end faces of the outer and inner ring are aligned (visually observed to be flush). **Maximum allowable hydraulic pressure is 450 bar!**
7. Tighten the ring counter nut by hand against the outer ring.
8. Release the hydraulic pressure. The ring nut will then be tightly pressed against the outer ring due to the stored energy.
9. Replace the screw plugs to retain the hydraulic oil in the shrink disc.

Dismounting

1. Remove screw plugs from the "Spannen" (Tighten) and "Entspannen" (Loosen) connections. Collect any oil leakage.
2. Connect hydraulic pump to the "Spannen" (Tighten) connection. Increase the hydraulic pressure (max. 450 bar!) until the ring nut can be loosened by hand.



Make sure that a minimum of two turns remain connected when loosening the ring nut. Otherwise the nut might fall off! This could be dangerous and result in injury.

3. Release the hydraulic pressure and then connect pump to the "Entspannen" (Loosen) connection.
4. Increasing the oil pressure (**max. 450 bar!**) will initiate the release of the connection. **As soon as the outer ring starts sliding towards the ring nut reduce the oil pressure immediately to max. 150 bar.** When the outer ring reaches the support ring the oil pressure will automatically increase. **At this point fully release the oil pressure. Make sure the oil pressure does not exceed 180 bar.**
5. The connection is loose now. Collect oil leakage coming out of the "Spannen" (Tighten) connection.
6. Leave all hydraulic oil within the shrink disc and replace the "Spannen" (Tighten) and "Entspannen" (Loosen) screw plugs so that the shrink disc is oil tight.
7. Remove the shaft or slide the hub off the shaft. Prior to removal clean off any rust from the shaft in the immediate vicinity of the hub.
8. Remove the shrink disc off the hub.