



Tank heaters are suitable for preheating hydraulic, lubricating oil and temperature systems in order to avoid breakdowns which may be caused by a medium with insufficient temperature. With a too low starting temperature of the medium, the viscosity is higher than during the operating temperature. This may cause friction and cavitation on pumps and motors the consequence of which is an earlier wear of the components and a reduction of the service life of the overall system.

General Hints

Please read through these mounting instructions carefully before you set the tank heaters into operation. Please pay special attention to the safety instructions! The mounting instructions are part of your product. Please keep them carefully and close to the tank heaters. The copyright for these mounting instructions remains with **KTR Kupplungstechnik GmbH**.

Safety and Advice Hints



DANGER!

Danger of injury to persons.



CAUTION!

Damages on the machine possible.



ATTENTION!

Pointing to important items.

General Hints of Danger



DANGER!

With the assembly, operation and maintenance of the tank heater please make sure that the entire drive train is secured against inadvertent starting and the system is unpressurized. You may be seriously hurt by hot or pressurized hydraulic oil or the hot tank heater. For that reason please make absolutely sure to read through and adhere to the following safety hints.

- All operations on and with the tank heaters have to be performed taking into account "**safety first**".
- Please make sure to disengage the power pack before you perform your work.
- Protect the power pack against unintentional engagement, e. g. by providing hints at the place of engagement or removing the fuse for current supply.

Proper Use

You may only assemble, operate and maintain the tank heaters if you

- have carefully read through the mounting instructions and understood them
- had technical training
- are authorized to do so by your company

The **tank heaters** may only be used in accordance with the technical data. Unauthorized modifications on the tank heaters design are not admissible. We do not take any warranty for resulting damages. To further develop the product we reserve the right for technical modifications.

The **tank heaters** described in here corresponds to the technical status at the time of printing of these mounting instructions.

Schutzvermerk ISO 16016 beachten.	Gezeichnet: 10.02.10 Pz/Ha	Ersatz für: KTR-N vom 28.03.07
	Geprüft: 10.02.10 Pz	Ersetzt durch:



Assembly – Type EHP (Inserted Heating Cartridges)

During assembly please pay attention to the following procedures:

- The inserted heating cartridge is to be assembled to the counter flange by means of a gasket suitable for the liquid. If possible, the screwed cable gland should point downwards.
- Screw the inserted heating cartridge horizontally below oil level into the bushing to fit in the tank. Minimum oil level is 50 mm over heating tube.
- For devices with temperature control the user is responsible for the setting of the cutoff temperature (switching accuracy $\pm 3\text{ }^{\circ}\text{C}$).
- Replaceable ceramic heating inserts (assembly without oil drain).
- The permissible surface load of the medium has to be reviewed and assured by the user.



ATTENTION!

For devices without integrated temperature control a separate (external) temperature control is necessary (see KTR industrial control).

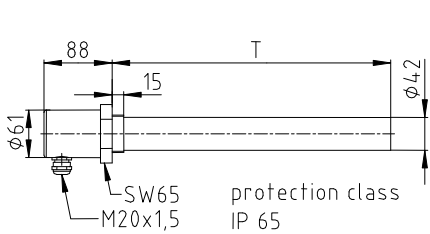

picture 1: type EHP – G 1 1/2" without temperature control

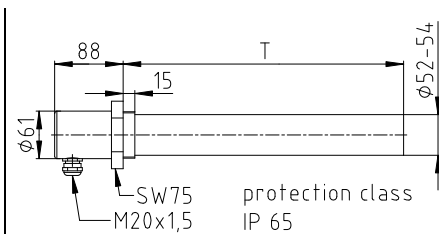

picture 2: type EHP – G 2" without temperature control

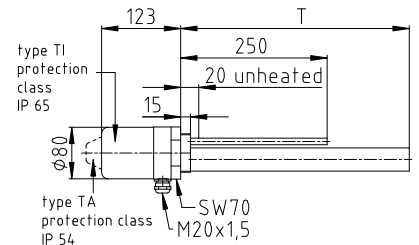

picture 3: type EHP (TA/TI) – G 2" with temperature control

Technical Details of the Device – Type EHP (Inserted Heating Cartridges)

The standard devices listed in table 1 are selected for hydraulic oils with a permissible surface load of $1,5\text{ W/cm}^2$.

Tabelle 1: Abmessungen – Technische Daten EHP

type EHP G 1 1/2" without temperature control	heating capacity	immer- sion depth T	voltage	type EHP G 2" without temperature control	heating capacity	immer- sion depth T	voltage	type EHP (TA/TI) G 2" with temperature control	heating capacity	immer- sion depth T	voltage
	[Watt]	[mm]	[V]		[Watt]	[mm]	[V]		[Watt]	[mm]	[V]
	400	200	230		500	200	230		450	300	230
	600	300	230		750	300	230		600	400	230
	800	400	230		1000	400	230		750	500	230
	1000	500	230		1250	500	230		900	600	230
	1200	600	230		1450	600	230		1050	700	230
	1400	700	230		1700	700	230		1200	800	230
	1600	800	230		1950	800	230		1350	900	230
	1800	900	230		2200	900	230		1500	1000	230
	2000	1000	230		2450	1000	230		1650	1100	230
	2200	1100	230		2700	1100	230		1800	1200	230
	2400	1200	230		2950	1200	230		1950	1300	230
	2800	1400	230		3450	1400	3x400		2100	1400	230
	3200	1600	230		3900	1600	3x400		2250	1500	230
	3600	1800	3x400		4400	1800	3x400		2400	1600	230
	4000	2000	3x400		4900	2000	3x400				



Storage and transport – type EH (inserted tubular heaters)

Please note the following items for storage or transport, respectively:

- The heaters have to be stored in dry condition with a temperature of approx. 20 °C.
- The storage period should not exceed 5 - 6 months.
- Only dry packaging material should be used for transport.
- In case of a second drying process subject to negative insulating figures, the heaters should be placed in a drying stove at approx. 100 - 120 °C overnight. Having cooled down the heaters can normally be used without any problems.

Assembly – Type EH (Inserted tubular heaters)

During assembly please pay attention to the following procedures:

- The inserted tubular heating is to be assembled to the counter flange by means of a gasket suitable for the liquid. If possible, the screwed cable gland should point downwards.
- Screw the inserted tubular heating horizontally below oil level into the bushing to fit in the tank. Minimum oil level is 50 mm over heating tube.
- For devices with temperature control the user is responsible for the setting of the cutoff temperature (switching accuracy ± 3 °C).
- The permissible surface load of the medium has to be reviewed and assured by the user.



ATTENTION!

For devices without integrated temperature control a separate (external) temperature control is necessary (see KTR industrial control).



ATTENTION!

Generally defective devices can only be replaced after the tank has been fully drained off.

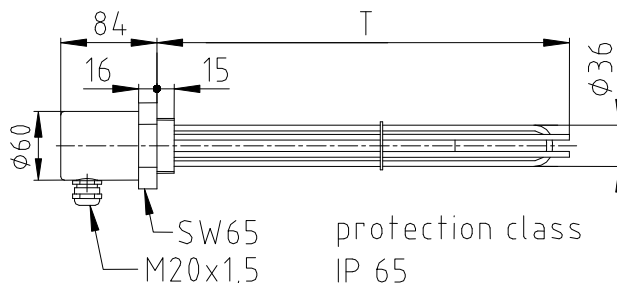

picture 4: type EH – G 1 1/2" without temperature control

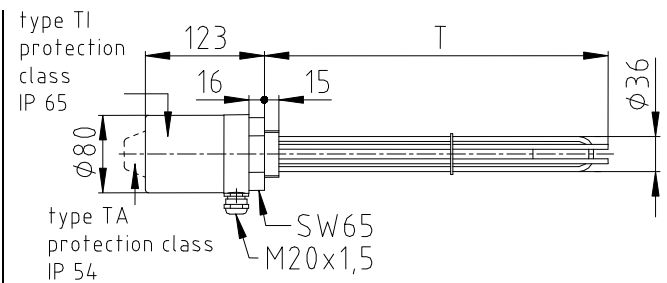

picture 5: type EH (TA/TI) – G 1 1/2" with temperature control for external or internal setting, respectively

Technical Details of the Device – Type EH (Inserted tubular heaters)

The standard devices listed in table 2 are selected for hydraulic oils with a permissible surface load of 1,5 W/cm².

Table 2: Dimensions – Technical Data EH

type EHP (TA/TI) G 1 1/2" without or with temperature control	heating capacity [Watt]	immersion depth T [mm]	voltage [V]
	380	200	230
	500	250	230
	750	350	230
	990	450	230
	1460	650	230
	1825	800	230
2300	1000	230	

Schutzvermerk ISO 16016 beachten.	Gezeichnet: 10.02.10 Pz/Ha	Ersatz für: KTR-N vom 28.03.07
	Geprüft: 10.02.10 Pz	Ersetzt durch:



General Data – Type TEHM (Inserted tank heater)

Description of product

The threaded tubular heaters serve for preheating hydraulic oil in order to avoid breakdowns which may arise on machine tools, presses, hydraulic lifts, etc. due to cooling of the hydraulic systems.



Assembly – Type TEHM (Inserted tank heater)

During assembly please pay attention to the following procedures:

- The permissible surface load for hydraulic oil on a mineral basis with standard devices is 1,2 W/cm². Devices with 0,6 W/cm² are available on request.
- The temperature control of the standard devices is performed by an integrated controller with a pre-set cutoff temperature of 20 °C. With a switching precision of ± 3 °C the device is set into operation again with approx. 17 °C.
- The tank heater is installed either horizontally to the tank ground or vertically to the tank wall by means of magnetic clamps. It has to be made sure that the tank heater is generally assembled below oil level. It has to be excluded that the tank heater is running at dry operation. The service cable is led outside either through the tank wall or the cover to be fastened to the corresponding screwed cable gland.
- Electrical connection to be installed as per the attached connection diagram (see pictures 7 to 10) by experts only.

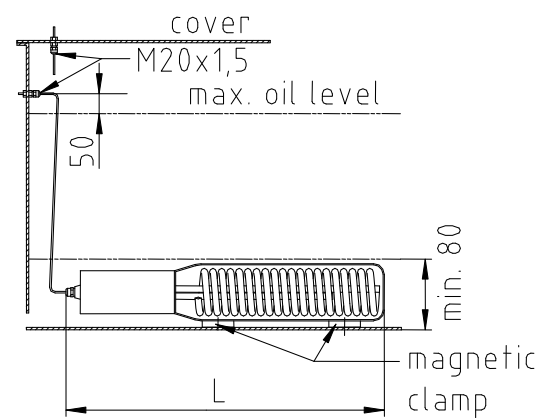

picture 6: installation diagram – TEHM

Technical Details of the Device – Type TEHM (Inserted tank heater)



ATTENTION!

The permissible surface load of the medium has to be reviewed and assured by the user.

Table 3: Dimensions – Technical Data TEHM

type TEHM	heating capacity	overall length L	voltage
	[Watt]	[mm]	[V]
	250	265	230
	500	290	230
1000	400	230	



Electrical Connections

A supply line as per the ambient temperatures arising has to be used. The cross-section has to be dimensioned according to VDE 0100. A connection diagram of the inserted heating cartridge is attached in the connection housing loosely.

The temperature controls have to be set to the requested operating temperature by the customer.

In case that a safety temperature limitation exists:

In case of a failure of the thermostat the safety temperature limitation fully switches off the system and may only be set into operation by an expert again after the failure has been repaired.

The devices may be connected to the following supply voltages:

Connection to 200 V/230 V (1-phase alternating current) and to

2x400 V/2x380 V (2-phase alternating current)

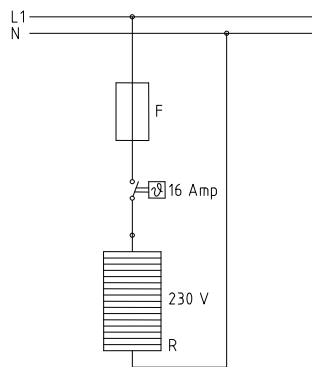

picture 7: connection diagram with thermostat – 230 V

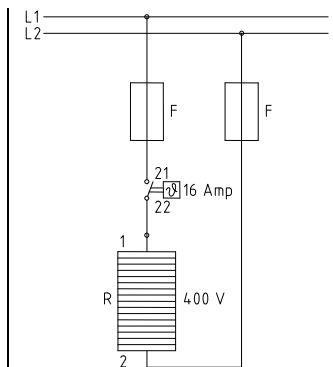

picture 8: connection diagram with thermostat – 400 V

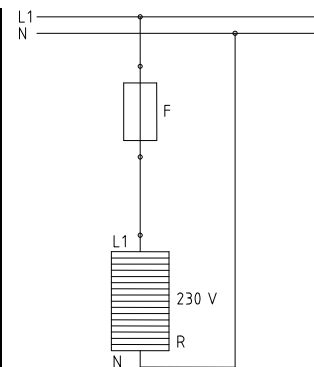

picture 9: connection diagram without thermostat – 230 V

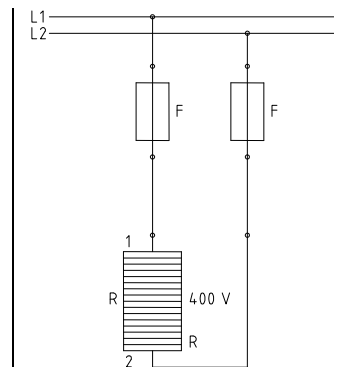

picture 10: connection diagram without thermostat – 400 V

Connection to three-phase current with star connection \star 220 V/230 V and to

three-phase current with delta connection \triangle 400 V/380 V

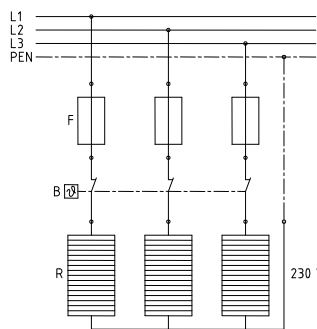

picture 11: connection diagram with thermostat – 230 V \star

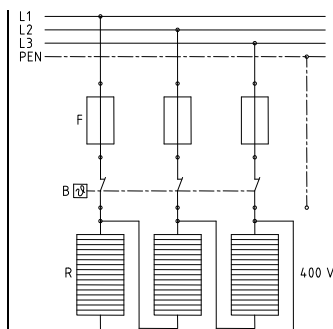

picture 12: connection diagram with thermostat – 400 V \triangle

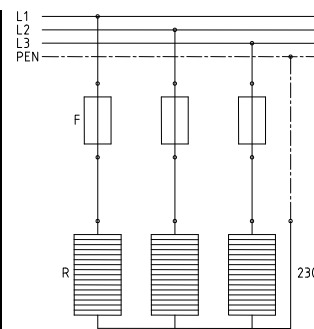

picture 13: connection diagram without thermostat – 230 V \star

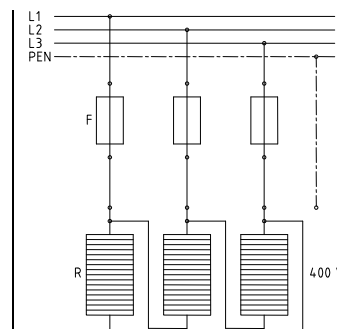

picture 14: connection diagram without thermostat – 400 V \triangle

Symbol for contact units and switching devices:

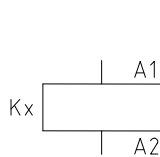

picture 15: protection

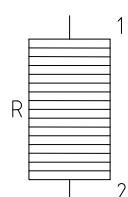

picture 16: filament resistance



picture 17: connection pins

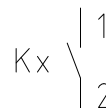

picture 18: earthing contact

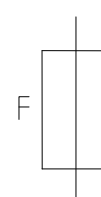

picture 19: fuse

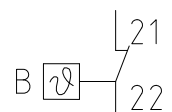

picture 20: thermostat

Schutzvermerk ISO 16016 beachten.	Gezeichnet: 10.02.10 Pz/Ha	Ersatz für: KTR-N vom 28.03.07
	Geprüft: 10.02.10 Pz	Ersetzt durch:



Electrical Connections



ATTENTION!

Perform the installation of the electrical connection as per the attached connection diagram (see page 5).



CAUTION!

The electrical connection may only be installed by experts. The necessary rules have to be obeyed.

Set-point Adjustment



CAUTION!

All necessary settings and potential corrective actions are described in the operating instructions you have on hand. If, nevertheless, difficulties arise when the device is set into operation, we would ask you not to perform any illegal interventions on the device. Otherwise you might risk your warranty claim. Please contact KTR Kupplungstechnik.

Maintenance

After an operation period of 1 month all current supply terminals have to be retightened. Here the terminals for the supply lines of the heating elements have to be retightened, too. Another maintenance is not necessary.

Production of coating

We would recommend to review the coating in regular intervals. If necessary, the coating has to be removed.



ATTENTION!

The claim for warranty extinguishes with failures caused by coating and corrosion.

Schutzvermerk ISO 16016 beachten.	Gezeichnet: 10.02.10 Pz/Ha	Ersatz für: KTR-N vom 28.03.07
	Geprüft: 10.02.10 Pz	Ersetzt durch: